

ELECTRA

TL Touch Line

4 Wires

Residential

Audio **smart+**



3.5" Video **smart+**



7" Video **smart+**



7" Video **extra**

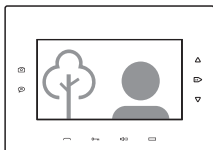

AUDIO & VIDEO TERMINALS
for TL door phone systems-
4 WIRES-RESIDENTIAL
User manual

EN

0 Contents

- 1 Safety instructions
- 2 Description of the audio-video terminals
- 3 Functions of the audio-video terminals
- 4 Recommended cables. Installation.
- 5 Use of the audio-video terminals
- 6 Settings of the audio-video terminals
- 7 Programming the audio-video terminals
- 8 Use of the outdoor panels
- 9 Maintenance of the door phone components
- 10 Warranty

1 Safety instructions



Any intervention on the installation must be performed by **AUTHORIZED PERSONNEL!**
DO NOT power the product at 110 – 230 Va.c!
DO NOT hit the glass screen with hard objects!
If the glass screen is broken, **DO NOT** touch the product.
Protect the products against lime and dust during renovation activities.

2 Description of the audio-video terminals

4 WIRES / RESIDENTIAL

EN
1

smart+ audio terminal ATM.0S402

ABS case
+ chemically toughened glass



170x96x22 mm
0,3 kg

0°C ... + 45°C
IP31

+U = 12 ... 14 Vd.c.

smart+ video terminal VTM.3S402

ABS case
+ chemically toughened glass



3.5" LCD TFT 320 (RGB) x 240

212x96x22 mm
0,4 kg

0°C ... + 45°C
IP31

+U = 12 ... 14 Vd.c.

smart+ video terminal VTM.7S402

ABS case
+ chemically toughened glass



7" LCD, TFT, 800 x 3 (RGB) x 480
◀/▶/▲/▼ - 60 / 60 / 40 / 60

162x227x20 mm
0,8 kg

0°C ... + 45°C
IP31

+U = 12 ... 14 Vd.c.

extra video terminal VTE.7S902

ABS case
+ chemically toughened glass



7" LCD, TFT, 800 x 3 (RGB) x 480
◀/▶/▲/▼ - 60 / 60 / 40 / 60

162x227x20 mm
0,8 kg

0°C ... + 45°C
IP31

+U = 12 ... 14 Vd.c.

3 Functions of the 4 WIRES / RESIDENTIAL terminals

Main functions

- Call, answer and hands-free talk (full-duplex talk). Audio-video monitoring.
- Video image display during the call, talk, monitoring and access
- Access command during call, talk and monitoring
- Additional command – AUX key for an auxiliary automation

Additionally, only for the extra video terminals

- Picture taking during call, talk and monitoring
- Picture memory of up to 100 images. Visualize/ delete pictures

Settings

- Call and talk volume adjustment: 7 levels and silent (mute)
- Ringtone selection: 5 options
- Call duration selection: 1 x 5 sec., 2 x 5 sec., 3 x 5 sec. or 1 min. continuously
- Video image adjustment: brightness, chrominance
- Date and Time setting and display

Extensions

- Auxiliary command: auto gate, garage door, outdoor lighting etc.
- Successive video monitoring, when additional video cameras are connected
- 1 additional video terminal and/or 3 additional audio terminals, connected to the main terminal
- The doorbell at the entrance and a GONG can be connected directly to the terminal.

EN

2

4 Recommended cables.

4 WIRE Installation

- 4 wires x 0.5 mm² (type H03W-F4G 0.5) for maximum 75 ml or another type of equivalent cable
- 4 wires x 0.75 mm² (type H05W-F4G 0.75) for maximum 100 ml or another type of equivalent cable
- Generally, any type of 4-wire cable with a 0.5 mm section is accepted. **Telephone cables** type TCYY - 2x2x0.5-24 AWG (max. 30ml); TCYY - 3x2x0.5-24 AWG (max. 50ml); TCYY - 4x2x0.5-24 AWG (max. 100ml) can also be used.

Note: If your cable has more than 4 wires, the additional wires will be connected the same as in the case of a **UTP cable - screw connections** from the **RESIDENTIAL** installation (below). The **+U** and **GND** connections are equally supplemented with the additional wires.



RESIDENTIAL Installation

- For distances between 150 lm and 1000 lm it is mandatory to use the twisted pair cable type: **UTP cat5e (AWG24) / FTP cat5e (AWG24)** or: **UTP cat6 (AWG23) / FTP cat6a (AWG23)**. The connection of the audio-video terminals to the installation is done with a RJ45 connector or with screw connectors.

RJ45

1. White-Orange
2. Orange
3. White-Green
4. Blue
5. White-Blue
6. Green
7. White-Brown
8. Brown

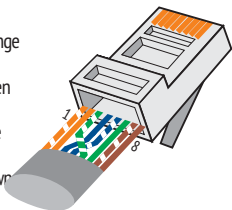

Screw connections

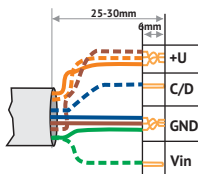

4.1 Installation of the smart+ Audio / 3.5" Video Terminal - 4 WIRES

STEP 1

Fasten the back case on the wall H=135cm
Fasten the connectors on the back case

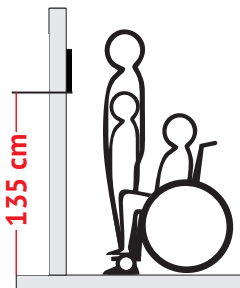

STEP 2

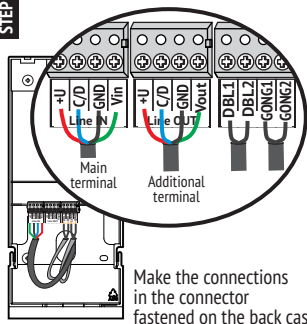

Make the connections in the connector fastened on the back case.

Connection diagram for the AUDIO terminal - 4 WIRES

EN
3

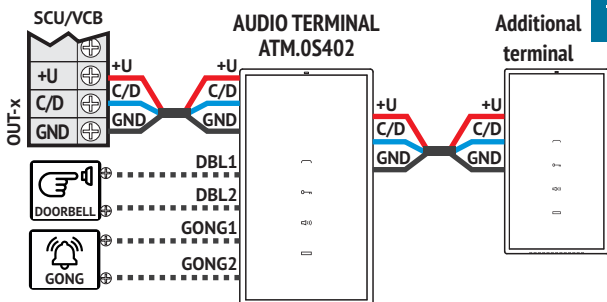

Connection diagram for the 3.5" VIDEO terminal - 4 WIRES

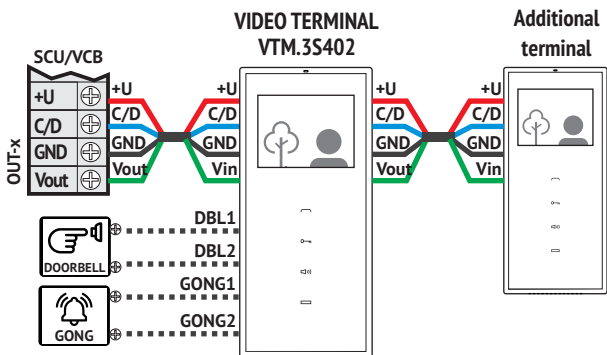

4.2 Installation of the smart+ / extra 7" Video Terminal - 4 WIRES

STEP 1

Fasten the back case on the wall H=135cm
Fasten the connectors on the back case

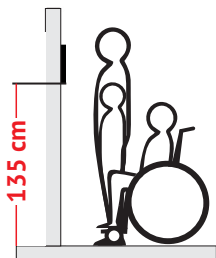

STEP 2

Make the connections in the connector fastened on the back case.

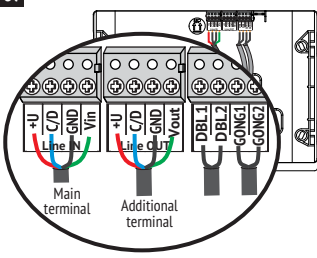

Connection diagram for the 7" VIDEO terminal - 4 WIRES

EN

4

VIDEO TERMINALS VTM.7S402/VTE.7S902

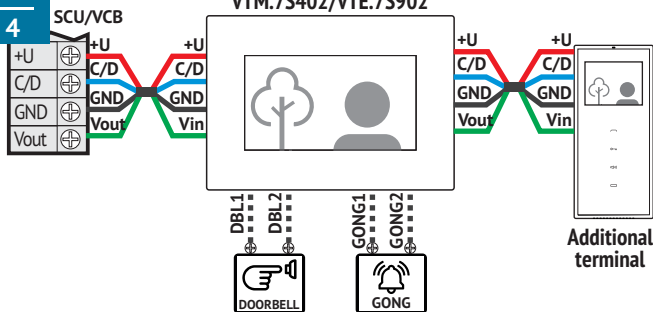

The wall-mounting of the audio-video terminals - 4 WIRES / RESIDENTIAL

STEP 3

1. Place the 3.5" front case with the fastened connectors over the back case.
2. Pull the terminal down until it interlocks.

1. Place the 7" front case with the fastened connectors over the back case.
2. Pull the terminal down until it interlocks.

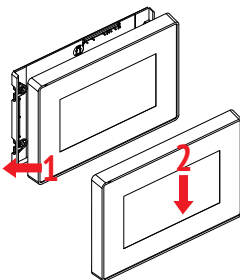
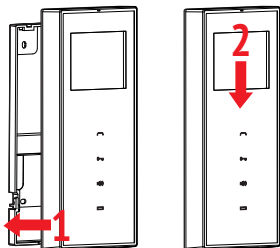

4.3 Installation of the audio-video terminals - RESIDENTIAL

For distances between 150 lm and 1000 lm it is mandatory to use the twisted pair cable type: UTP cat5e (AWG24) / FTP cat5e (AWG24) or: UTP cat6 (AWG23) / FTP cat6a (AWG23).

The **TL smart+** or **extra AUDIO-VIDEO TERMINAL** can be connected to the RESIDENTIAL installation in one of the following ways:

a. Through a RJ45 connector. A special type of pliers for UTP-RJ45 connections will be used.

The wires of the UTP cable in the RJ45 connector will have the following connection order, from left to right:

1. White-Orange
2. Orange
3. White-Green
4. Blue
5. White-Blue
6. Green
7. White-Brown
8. Brown

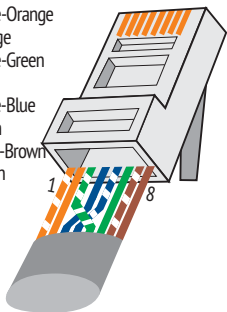

The RJ45 connector will be inserted in the female RJ45 connector of the terminal, as shown in the image below.

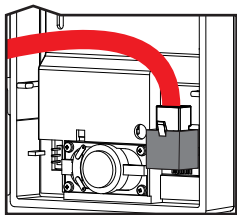

b. Through a screw connector. A 2x0.4 flat-head screwdriver will be used. The UTP cable is prepared and connected to the terminal as indicated in the drawing below.

The order in which the UTP wires should be connected to the screw connector is the following:

+U (13,5Vd.c.): The Orange and White-Orange wires

C/D (audio/data communication): The White-Blue wire

GND (0.0Vd.c. mass): The Brown, White-Brown, Blue and Green wires

Vin (PAL, 1V v.v. video): The Green-White wire

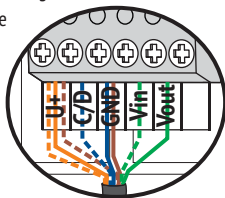

NOTE: The **ADDITIONAL TERMINAL** will be connected to the **main terminal** following the same wire color order and terminal meaning.

The Green-White wire for the video signal will leave from the **Vout** terminal of the main terminal.

The **TL smart AUDIO TERMINAL** follows the below order of connecting the UTP wires to the screw connector:

+U (13,5Vd.c.): The Orange and White-Orange wires

C/D (audio/data communication): The White-Blue wire

GND (electric signal mass): The Brown, White-Brown, Blue wires

The Green-White pair will not be connected. It will be cut from the edge of the cable wrap.

The **DOORBELL** and **GONG** are connected to the video or audio terminal through any type of isolated copper cable (2x0.5 mm).

The **DBL1** and **DBL2** connectors take the electric signal from a doorbell (DOORBELL) from the entrance to the apartment.

The **GNG1** and **GNG2** connectors trigger a GONG device through a relay, in order to have a more powerful call at longer distances from the main terminal.

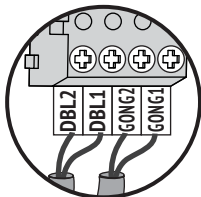

5 Use of the audio-video terminals

5.1 Use of the smart+ terminals

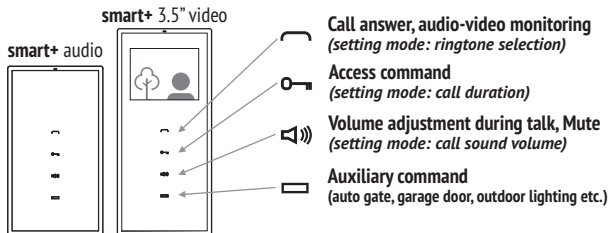

Call answer, audio-video monitoring
(setting mode: ringtone selection)

Access command
(setting mode: call duration)

Volume adjustment during talk, Mute
(setting mode: call sound volume)

Auxiliary command
(auto gate, garage door, outdoor lighting etc.)

smart+ 7" video

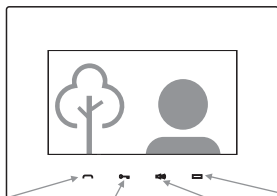

Call answer,
audio-video monitoring
(setting mode:
ringtone selection)

Access command
(setting mode:
call duration)

Volume adjustment
during talk, Mute
(setting mode:
call sound volume)

Auxiliary command
(auto gate,
garage door,
outdoor lighting etc.)

EN

6

Standard settings of the producer:

1.	Ringtone		Ding-dong (first in the list)
2.	Call duration		2 calls
3.	Call sound volume		Level 5 out of 7

1. STAND-BY: The keyboard is not backlit.

2. CALL FROM THE OUTDOOR PANEL: The terminal rings for maximum 1 min., with the selected ringtone. All the keys light up, and the key blinks. The display shows the image with the visitor.

- During the call, the conversations that take place indoors cannot be heard outdoors.

- You can hear and see what goes on at the entrance!

Volume adjustment during CALL: Successively touch the key. The maximum level (7) is signaled with two beeps (2 x [BEEP]). After the maximum level is reached, the adjustment recommences at level 1. *This adjustment will not be stored. All the calls will start with the set level for the call sound volume (see the settings section).*

3. CALL FROM THE DOORBELL OF THE RESIDENCE. The terminal rings with a specified ringtone, set by the producer. The video display remains turned off.

4. CALL ANSWER + TALK. To answer and initiate the talk, press the key, which will remain permanently backlit. The talk takes place hands-free, during maximum 2 min.

- The talk may be ended without granting access, by touching the key.

The image closes and the keys remain backlit for 10 more sec. Volume adjustment during **TALK**: Successively press the speaker key - . The maximum level (7) is signaled with two beeps (2 x ^{BEEP}). After the maximum level is reached, the adjustment recommences at level 1.

5. ACCESS COMMAND. DOOR/ GATE OPENING. From the terminal, you may control the opening of the door/gate, in the following situations:

a. During TALK. If you decide to grant access to the visitors, touch the  key. The terminal remains on for 10 more sec. You can hear and see what goes on at the entrance!

b. During audio-video MONITORING. If you decide to open the door/gate, touch the  key. The terminal remains on for 10 more sec. You can hear and see what goes on at the entrance!

c. In STAND-BY mode. If you decide to open the door/gate, **long touch** (2-3 sec.) the  key. The terminal remains on for 10 more sec. You can hear and see what goes on at the entrance!



6. ADDITIONAL "AUX" COMMAND. The **Touch Line** door phones allow the connection of an additional automation to the **AUX** terminals of the central unit: auto gate, garage door, outdoor lighting system etc. If such an automation is connected, you may control it from the terminal through the  key. The **AUX** command can be performed in the following situations:

a. During TALK. If you decide to give the **AUX** command, touch the  key. The terminal remains on for 10 more sec. You can hear and see what goes on at the entrance!

b. During audio-video MONITORING. If you decide to give the **AUX** command, press the  key. The terminal remains on for 10 more sec. You can hear and see what goes on at the entrance!

c. In STAND-BY mode. If you decide to give the **AUX** command, **long touch** (2-3 sec.) the  key. The terminal remains on for 10 more sec. You can hear and see what goes on at the entrance!

7. AUDIO-VIDEO MONITORING. From the **STAND-BY** mode, touch the  key. Monitoring, video image + bidirectional talk last maximum 15 sec.

- During monitoring, you can see and hear what goes on at the entrance, you can talk two-ways and you may control **ACCESS** () and **AUX** ()

- *In a building with multiple apartments, simultaneous monitoring cannot be performed.*

8. AUDIO SILENT MODE (MUTE). If you do not want to be disturbed by visitors, from **STAND-BY** mode, **long touch** (2-3 sec.) the  key. The LED of the key turns on and remains permanently red. In case of a call, the image with the visitor is displayed, but the terminal does not ring.

- To exit the silent mode, short touch the  key. The LED becomes white again.

9. IMAGE ADJUSTMENT for the **smart+** VIDEO terminals.

This adjustment is made only if the colors on the display do not coincide with reality.

With the terminal in **MONITORING** mode, adjust the image with very small rotations of the **color** and **brightness** adjusters on the back of the terminal.

5.2 Use of the extra terminal

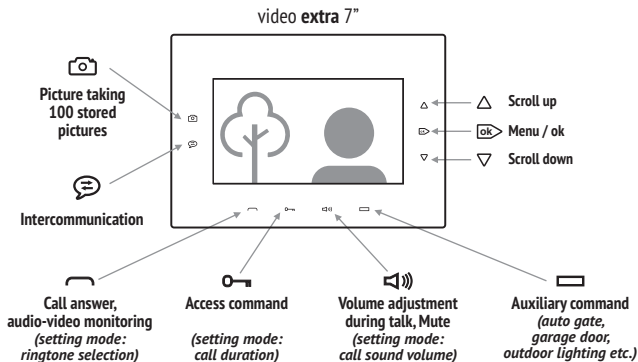

EN

8

NOTE: The extra video terminal fulfills all the smart+ functions (1-9), as well as the functions presented hereinafter.

10. PICTURE TAKING. At each call from the outdoor panel, the terminal automatically stores the picture of the visitor. During the talk, you can take additional pictures, by touching the key. The terminal can store maximum 100 pictures, and when the memory is full, the oldest pictures are deleted, on the **First In – First Out** principle.

11. VISUALIZE/DELETE PICTURES. • Touch the key and enter the **Menu**.

- Successively touch the key until you reach the **Pictures menu**.
- Using the ∇/Δ keys, choose **View Pictures** or **Delete all**. Press to select.
- In **View Pictures**, scroll using the ∇/Δ keys and visualize all the pictures.
- In **Delete all**, if you press the key, all pictures are deleted.

After 12 sec. of not using the **Menu** keys, the terminal automatically returns to the normal functioning mode.

12. IMAGE ADJUSTMENT for the extra VIDEO terminals. This adjustment is made only if the colors on the display do not coincide with reality.









- With the terminal operating, touch the key and enter the **Menu**.
- Successively touch the key, until you enter the **Display menu**.
- Scroll using the ∇/Δ keys and touch to select **Brightness, Chroma** or **Contrast**.
- Adjust the parameters using the ∇/Δ keys and touch to set the desired value. Select **Exit** to exit the **Display menu**.

13. INTERCOMMUNICATION. Short touch of . All the other terminals connected in parallel ring. The key (7") or the key (3.5" or audio) blinks white. For answering, short touch of (7") or (3.5" or audio). The intercommunication starts between the initiator terminal and the one of which were answered, for max. 1 min. For ending the intercommunication, another short touch of or .

**The intercommunication cannot be initiated from the 3.5" video or audio terminals connected in parallel, it can only be received.*

6 Settings of the audio-video terminals









6.1 1. CALL RINGTONE 2. CALL DURATION 3. CALL RINGTONE VOLUME

0	Long touch keys  ,  simultaneously. The terminal enters settings mode and issues a long warning beep. You have 2 min. available for settings 1, 2 and 3.
1	CALL RINGTONE • The first ringtone. Touch the  key. Listen to the first ringtone. • The second ringtone. Touch the  key again. The second ringtone will play. • For the third, the fourth and the fifth ringtone, repeat the procedure above. • The last played ringtone remains stored for the call.
2	CALL DURATION • The terminal rings only once. Touch the  key again. • The terminal rings twice. Touch the  key for the second time. • The terminal rings three times. Touch the  key for the third time. • The terminal rings continuously for 1 minute. Touch the  key for the fourth time. • The last played version remains stored for call.
3	CALL RINGTONE VOLUME • Successively touch the  key, until you reach the desired volume of the ringtone. Each volume level, from 1 to 7, is signaled by an increase in the intensity of the selected ringtone. • The last played version remains stored for the call.
4	• The settings mode will automatically close after 7 sec. from the last action.

EN

9

6.2 TIME and DATE setting for the extra terminal

- Touch the  key and enter the **Menu**.
- Continue to touch the  key until you reach the **Time & Date**.
- Scroll using the  /  keys and touch  to select the **Time** or the **Date**.
- Adjust the parameters using the  /  keys and touch the  key for the correct setting. Select **Exit** to exit the **Time & Date** menu.

7 Programming the audio-video terminals

The manual programming of the address of the terminal (apartment number/ family)

- All **Touch Line** terminals are programmed from the factory with **address 1**.
- The terminals from apartments with numbers from 2 to 9999 will be programmed with the number (address) of the respective apartment / family.
- The address of the terminals with numbers from 2 to 20 can be manually programmed, according to the following procedure:

0. The entire door phone system is installed and set under tension.

1. Go to the place where the **SCU** central unit of the installation is mounted. Long press (2-3 sec.) the **PROG** button. The red LED turns on.

2. Return to the terminal and long touch the  key. You will hear a long beep.

- Programming **address 1**: touch the  key **once**. A short beep is issued.

- Programming **address 2**: touch the  key **twice**. Two short beeps are issued.

- Programming **address 3**: touch the  key **three times**. Three short beeps are issued.

Repeat the procedure for the next addresses, until 20.

NOTE: After pressing the  key **n times**, wait a few seconds for the acoustic confirmation of the terminal for **address n**. The terminal will issue **n beeps** for **address n** programmed in the terminal.

3. Return to the **SCU** central unit of the installation. Press the **PROG** button for a short time. The red LED turns off. The installation returns to normal functioning mode.

- For programming the **Touch Line** terminals installed in buildings with a high number of apartments (higher than 15), purchase the special terminal address programming device from the producer.

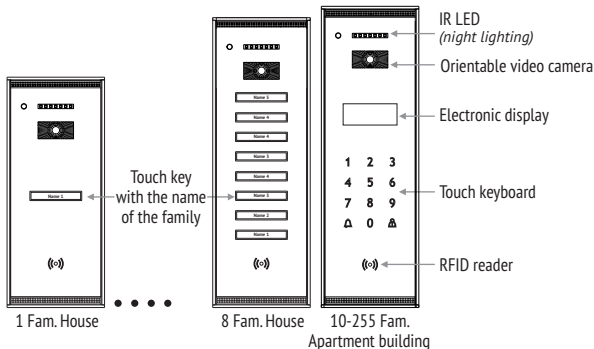

1. STAND-BY. The keys with the names of the residents/ the call keyboard are permanently backlit during night. The red LED blinks and signals the possibility of video monitoring.

2.1. CALL + TALK from outdoor panels with maximum 10 families. Touch the key corresponding to the name of the family you are looking for. The panel signals the action acoustically, with a ding-dong. The call lasts maximum 1 minute. Each touch of the key reinitiates the call. If the resident answers, the talk mode is activated. The talk takes place hands-free, during maximum 2 min.

2.2. CALL + TALK from outdoor panels for apartment buildings.

- Use the keyboard to dial the number of the desired apartment (maximum 4 digits). The panel signals the action acoustically, with ding-dong. The **Δ** key turns red and the following message appears on the display:

```

Calling:
Name1
To abort dial
Press Δ
  
```

- The call lasts maximum 1 minute.

If you do not know the number of the apartment, search for the name of the resident in the electronic list by touching the **Δ** key. Successively touch the **Δ** key until the name of the family and the apartment numbers show up on the display:

```

1:Name1
2:Name2
3:Name3
- Next page
  
```

If the resident answers, talk mode is initiated. The **Δ** key turns green and the following message is shown on the display:

```

SPEAK!
  
```

The conversation takes place hands-free, during maximum 2 min.

4. RFID card ACCESS. Approach the RFID card to the area marked with the **(•)** symbol. The panel commands the opening of the door/gate and issues a confirmation beep sequence. At the panel for apartment buildings, the display shows the following message:

The door/gate remains open for maximum 10 sec.

```

ACCESS
GRANTED
  
```

- The **Touch Line** audio-video terminals must be kept away from water, lime or any liquid substances, blows, fumes, powders, dust etc. In case of renovation activities, the entire surface of the terminals will be protected with plastic foil.
- The **Touch Line** outdoor panels must be kept away from corrosive substances, lime and blows.
- For cleaning the glass screens, use a clean cloth and a special solution for glass washing.
- DO NOT undo the electrical connections of the video door phone installation components.
- DO NOT short-circuit the electrical connections of the video door phone installation components.
- The accumulator, optionally connected to the central unit of the video door phone installation, must be replaced in case of defects or after exceeding its lifespan.

10 Warranty

a. Warranty is granted according to the current legislation in the buyer's country of residence, based on the purchase documents.

b. Warranty is granted for the hidden defects of the components used in production and in case of the system not functioning according to the present user manual.

WARRANTY IS NOT GRANTED FOR:

c. Inappropriate installation and use.

d. Deterioration, intentional blows.

e. Unauthorized interventions to any of the components of the installation.

f. Theft, fire, natural disasters.

g. Lack of protection of the installation components in case of renovation activities.

ELECTRA Building Communications GmbH
Bischoffgasse 5/3-4, 1120 Wien - **AT**

+43 1 810 20 99
✉ sales@electra-automation.at
🌐 www.electra-automation.at

ELECTRA s.r.l
Bd. Chimiei nr.8,Iași - 700291 - **RO**

+40 232 214.370 📠 +40 232 232.830
✉ sales@electra.ro
🌐 www.electra.ro

ELECTRA is a trademark of ELECTRA Group - No. 008958332 EUIPO - Alicante, Spain
ELECTRA products are registered as Industrial Models at EUIPO - Alicante, Spain

The products are
CE certified.



Certificate by
709

The products contain UL-compliant
printed circuit boards.



Certificate no. E307311

The products are manufactured under
Quality and Environment Management System

ISO 9001:2015
ISO 14001:2015

Certificates no. 73 100 4856, 73 104 4856
by TÜV HESSEN